

PRODUCT CATALOG



PRE-ENGINEERED
STEEL BUILDINGS



STORAGE
SOLUTIONS



PLANNING
& DESIGN



GENERAL CONTRACTING
& CONSTRUCTION

SUPPORT FOR YOUR LUMBER *AND* YOUR BUSINESS.



CONSTRUCTION PROVIDED BY



WE SUPPORT YOUR BUSINESS FROM THE GROUND UP.

For over a quarter of a century, Sunbelt Rack has supported LBM businesses throughout North America and the Caribbean with an extensive supply of storage solutions and steel buildings.

In partnership with our sister company, CT Darnell Construction, we offer you more of what you need to grow your business – from site planning and design to construction and general contracting.

Whatever we do for you, we promise creative solutions based on your individual needs, quality products, and a competitive price.

Maybe all you need today is traditional racking. But tomorrow you might need a whole lot more. Whatever you need, your Sunbelt Rack representative is happy to provide you with a preliminary plan or design and a quote.

Meanwhile, we hope this catalog will show you how we do whatever it takes to support your business from the ground up.



For advice or questions about anything in this catalog, please call or visit our website.



1-800-353-0892



Sunbelt-Rack.com



PRE-ENGINEERED STEEL BUILDINGS

Whatever your product mix and site conditions, we can provide just the right custom-designed pre-engineered steel buildings to meet them.



STORAGE SOLUTIONS

We'll design, create and install storage and material handling solutions that are right for your unique business needs, site and budget.



PLANNING & DESIGN

We offer custom planning and design for both new sites and renovations that provide solutions uniquely tailored to your LBM business.



GENERAL CONTRACTING & CONSTRUCTION

Whether you're building a new yard or renovating an existing one, we know what questions to ask to build the solutions your business needs.



TABLE OF CONTENTS

PRE-ENGINEERED STEEL BUILDINGS	4
STORAGE SOLUTIONS	24
PLANNING & DESIGN	52
GENERAL CONTRACTING & CONSTRUCTION	54



PRE-ENGINEERED STEEL BUILDINGS

We offer a wide variety of pre-engineered steel buildings custom designed to accommodate your product mix and site. We can provide engineered plans with installation throughout North America. Whether you need an office building, a retail building or a functional, efficient storage building such as a three-sided shed or drive-thru building, we have you covered.

For advice or questions about our pre-engineered steel buildings, please call or visit our website.



1-800-353-0892



Sunbelt-Rack.com

Section Table of Contents

- Store & Office Buildings 6
- Millwork Storage Buildings 8
- Three-Sided Sheds 10
- Umbrella Sheds 12
- Truss Buildings 12
- Loading Canopies 12
- Single-Aisle Drive-Thru Buildings 14
- Double-Aisle Drive-Thru Buildings 16
- Multiple-Aisle Drive-Thru Buildings 18
- Popular Drive-Thru Configurations 20
- Accessories 22



1982

LAUREY • BULLDOG MATERIALS • HILLTOPS
#1 Supplier to SE & VT

KUISEN
WELLSVILLE, VT

WELLSVILLE



STORE & OFFICE BUILDINGS

We provide pre-engineered steel buildings for LBM retail stores and office spaces – custom designed in any size or layout to suit your unique site and space requirements. Numerous options are available, including large clear spans, integral mezzanines, varied window and door configurations, metal siding and roofing color choices, skylights and insulation systems.

Features

- Available in any size or shape, tailored to your unique site and space requirements
- Can incorporate a mixture of retail, office, manufacturing and warehouse space
- Unlimited design options — both functional and aesthetic
- Engineered for your specific building code requirements
- Can be part of a comprehensive Sunbelt Rack yard and site layout (see *Planning & Design*, pg 52)
- Can incorporate Sunbelt Rack storage systems for maximum efficiency

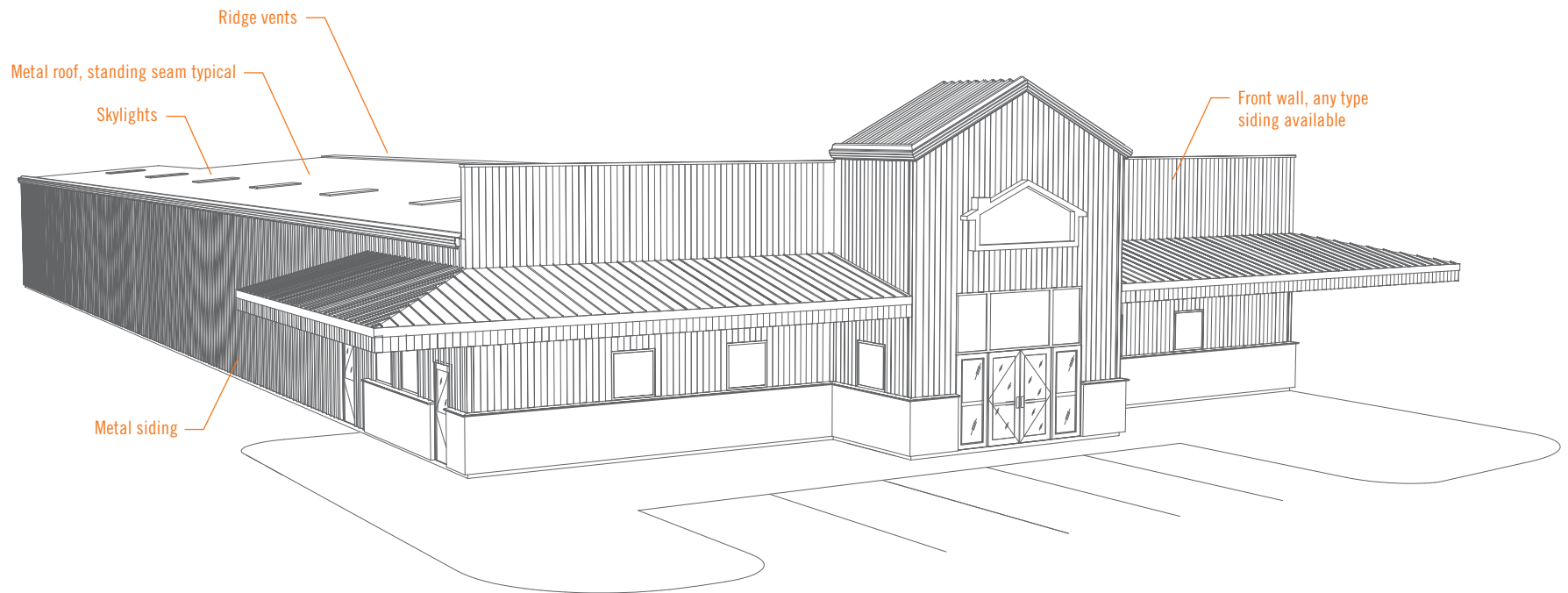

Reference the letter on the photo when speaking with your sales representative.



A



B



C



D



E



MILLWORK STORAGE BUILDINGS

Our steel buildings for millwork production and storage facilities are available in any size or layout, custom designed to work with assembly line layouts and inventory storage, staging and shipping requirements. Designs incorporate Sunbelt Rack systems to maximize material handling efficiencies and space utilization. Numerous options are available, including large clear spans, integral mezzanines, unique loading dock and truck well configurations, varied window and door layouts, metal siding and roofing color choices, skylights and insulation systems.

Features

- Available in any size or shape, tailored to your unique site and space requirements
- Can incorporate a mixture of retail, office, manufacturing and warehouse space
- Unlimited design options — both functional and aesthetic
- Engineered for your specific building code requirements
- Can be part of a comprehensive Sunbelt Rack yard and site layout (see *Planning & Design*, pg 52)
- Can incorporate Sunbelt Rack storage systems for maximum efficiency

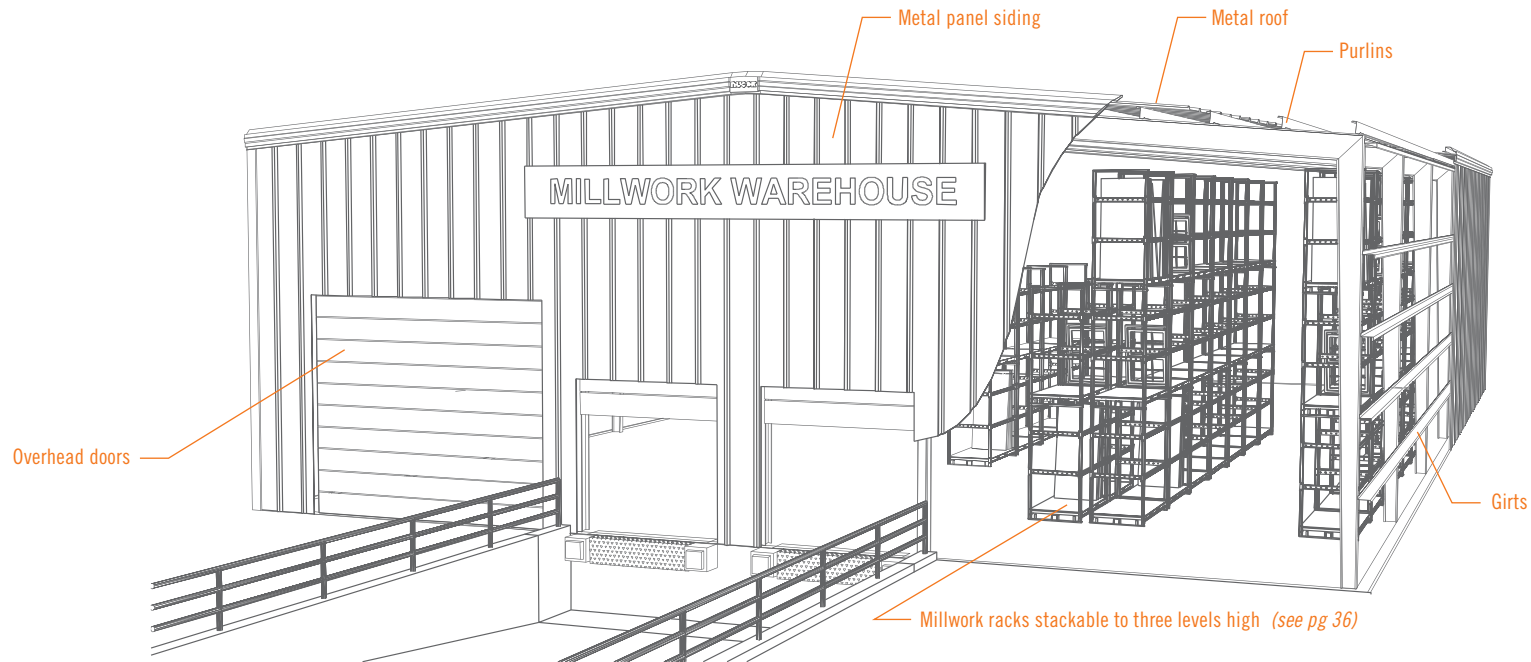

Reference the letter on the photo when speaking with your sales representative.



“
It’s great when we’re able to get involved on the front end of the process. Our designers have so much experience and we help our clients make informed decisions that will continue to pay off for years to come.
”
*Rick Stout, Senior Account Manager
CT Darnell Construction & Sunbelt Rack • Alpharetta, GA*





THREE-SIDED SHEDS

Our three-sided sheds are an economical way to store lumber, sheetrock, sheet goods and other bulk inventory. We can build them with full slab foundations or a simple pier design with a gravel floor, each one custom designed to suit your unique site and specific needs. We provide engineered plans throughout North America with unlimited design possibilities and options.

Features

- Economical storage for lumber, sheetrock and sheet goods
- Custom designed to suit your unique site and space requirements
- Available as multi-functional buildings, incorporating cantilever, pallet rack, A-frame racking and bulk storage areas
- Unlimited design possibilities and options
- Accessories available (see pg 22)

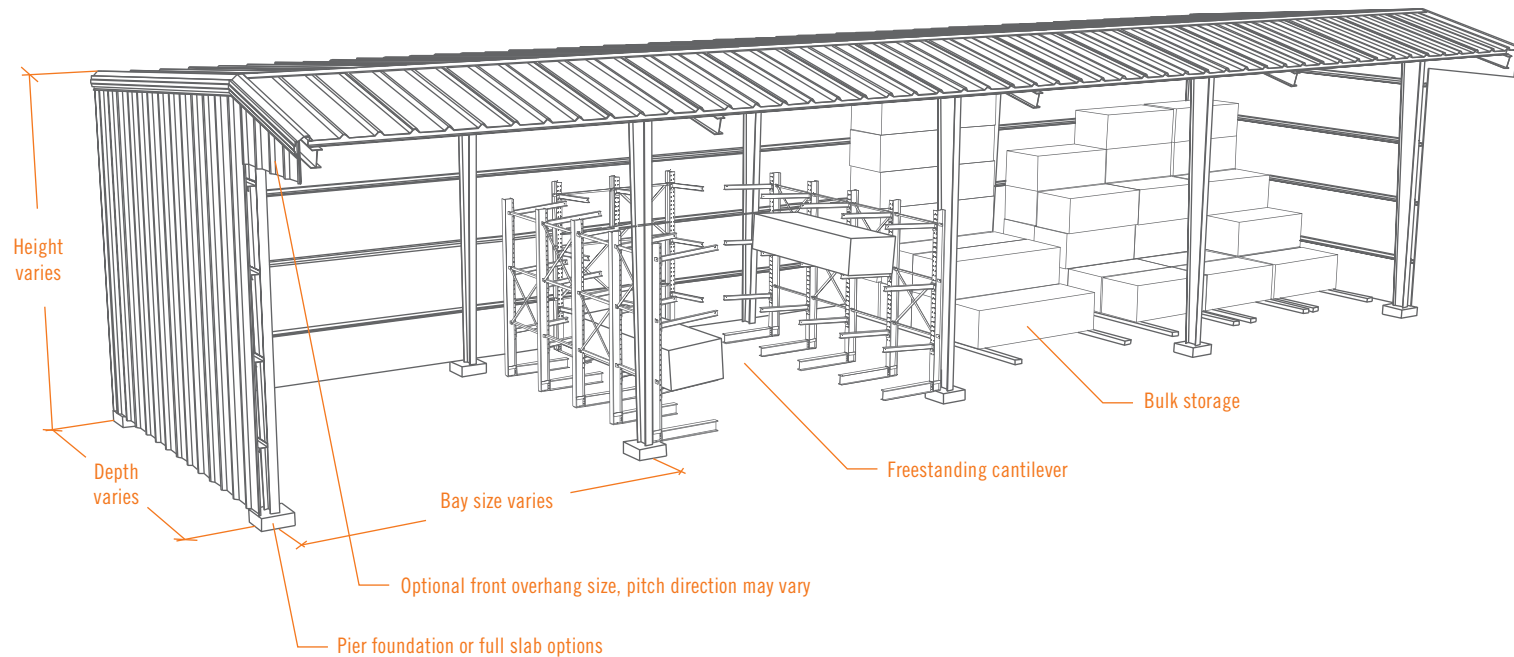

Reference the letter on the photo when speaking with your sales representative.



“
This is exactly what we love to do. We help our clients get the absolute most out of their available space. Sometimes we'll build the best solution from the ground up with new construction, or we'll design space-saving racking systems and customized warehouse buildings around the existing structure. Our main goal is maximum efficiency for their business.
”
Clint Darnell, Owner • CT Darnell Construction & Sunbelt Rack • Alpharetta, GA





UMBRELLA SHEDS

Our umbrella sheds are bulk storage buildings with no sidewalls, supported by one center column line. The roof gives bulk materials cover and shelter from the elements, while the lack of sidewalls allows material to be loaded and unloaded from both sides. Umbrella sheds are ideal for storing dimensional lumber, studs and OSB. They are available in any size configuration, with either full slab or pier foundations.

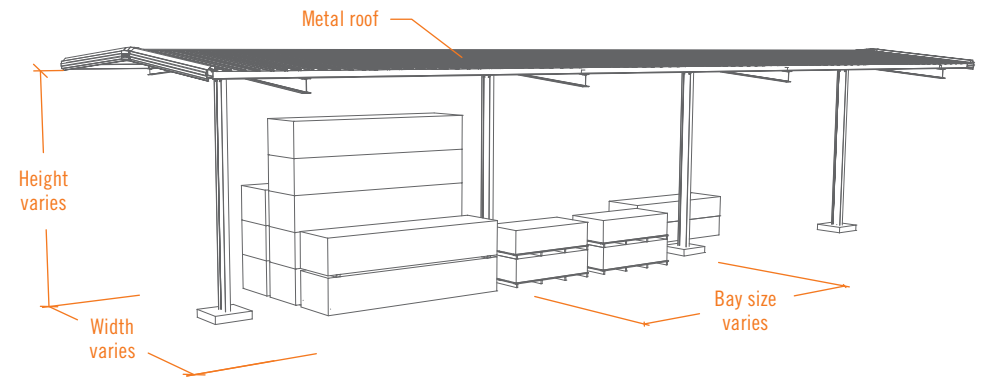

TRUSS BUILDINGS

We engineer truss buildings specifically for use in facilities that manufacture trusses or any other product that requires a large clear span. Truss buildings have an open front for ease of movement in and out of the building. They provide ample space for production areas, staging and storing of materials. Truss buildings can be easily customized with accessories such as skylights and lighting (see *Planning & Design*, pg 52).

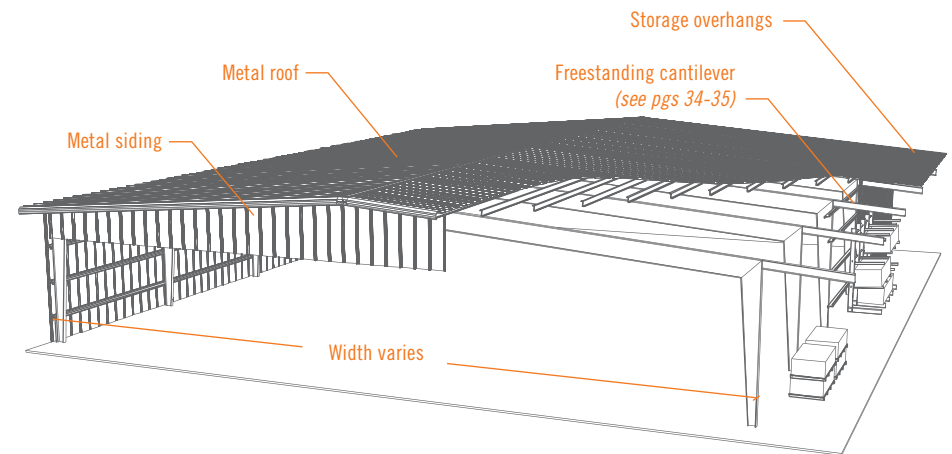

LOADING CANOPIES

Our loading canopies provide covered areas for shipping and receiving. We tailor each design to the types of materials being handled and the trucks and equipment being operated. We use smaller bay spacing and truck wells for box vans and wider clear

span bays for flat beds. Numerous options are available, including large clear spans, unique loading dock and truck well configurations, varied window and door layouts, metal siding and roofing color choices, and skylights.

Umbrella Shed

A D E F

Truss Building

B C

Reference the letter on the photo when speaking with your sales representative.





SINGLE-AISLE DRIVE-THRU BUILDINGS

Our drive-thru buildings provide economical, efficient high-density covered storage for building materials and lumber at lumberyards and home centers. These buildings store and organize a large quantity of materials by using steel rack systems to gain vertical storage and support the roof system. By integrating rack storage systems into their structure, we can construct our drive-thru buildings for less than the cost of separate buildings and rack systems.

Features

- Custom designed to suit your unique site and space requirements
- Available partially or completely enclosed
- Available as multi-functional buildings incorporating cantilever, pallet rack, A-frame racking, and bulk storage areas
- Accessories available (see pg 22)

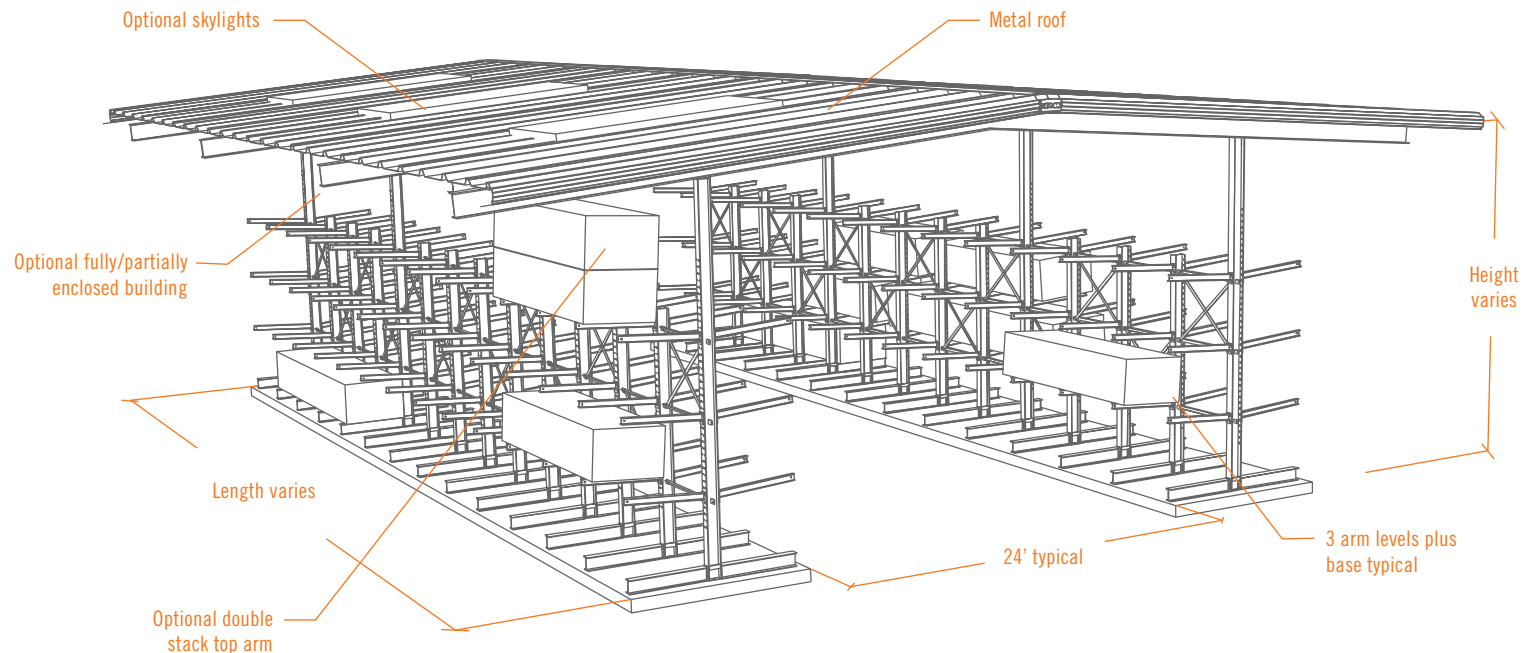

Reference the letter on the photo when speaking with your sales representative.



“
It is possible to lower your operating costs and increase your storage capacity. Sunbelt Rack has the products, service, and price. They delivered for us.
”
Doug LaBoube
McCray Lumber • Edwardsville, KS





DOUBLE-AISLE DRIVE-THRU BUILDINGS

Our double-aisle drive-thru buildings provide the same affordable, efficient high-density covered storage for building materials as our single-aisle drive-thru buildings but with two aisles. They are similarly custom designed for your specific product mix and site.

Features

- Custom designed to suit your unique site and space requirements
- Available partially or completely enclosed
- Available as multi-functional buildings incorporating cantilever, pallet rack, A-frame racking, and bulk storage areas
- Accessories available (see pg 22)

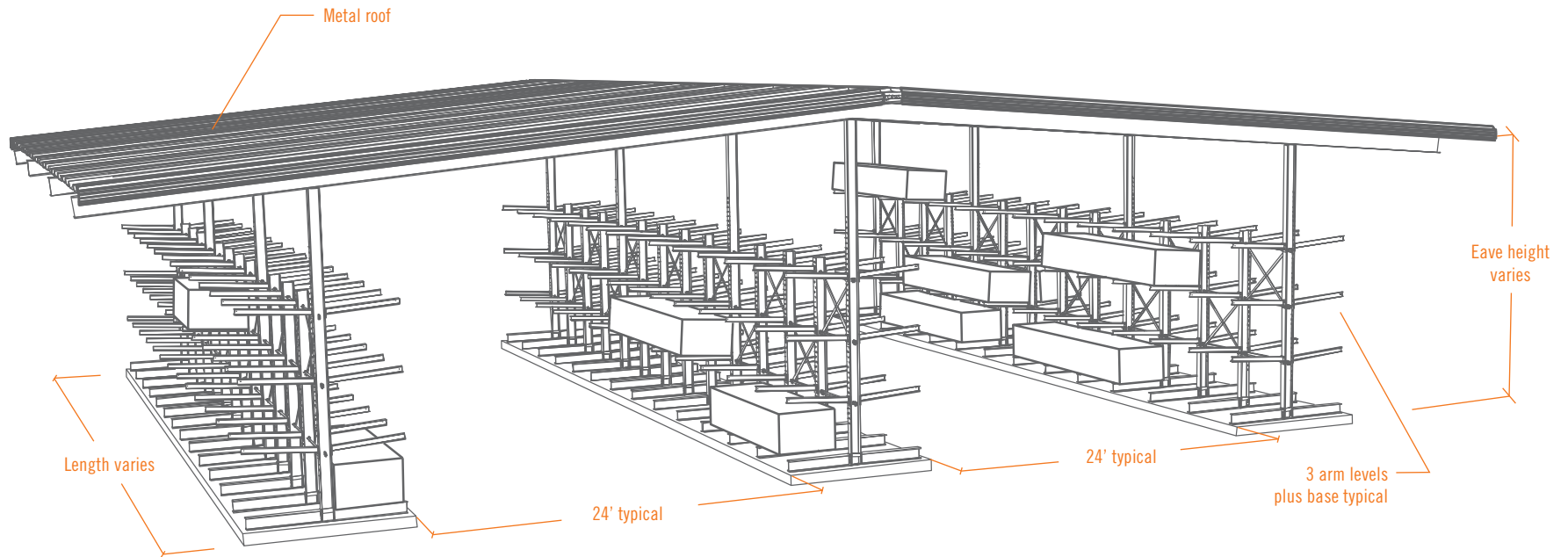

Reference the letter on the photo when speaking with your sales representative.



“
Working with Sunbelt Rack and CT Darnell Construction was great. The design process and implementation was painless and the crew was excellent. Not only was it on time and on budget – it even cost less than expected since they included the erection of the building and all the equipment in their proposal.
”

*Terrill Bartlett, Co-owner
Bartlett Lumber & Hardware • Canadian, TX*





MULTIPLE-AISLE DRIVE-THRU BUILDINGS

Our multiple-aisle drive-thru buildings provide the same affordable, efficient high-density covered storage for building materials and lumber as our single- and double-aisle drive-thru buildings, but with more aisles and more storage space. They are all custom designed for your specific product mix and land.

Features

- Custom designed to suit your unique site and space requirements
- Available partially or completely enclosed
- Available as multi-functional buildings incorporating cantilever, pallet rack, A-frame racking, and bulk storage areas
- Accessories available (*see pg 22*)

For popular configurations, see page 21, buildings H and I.

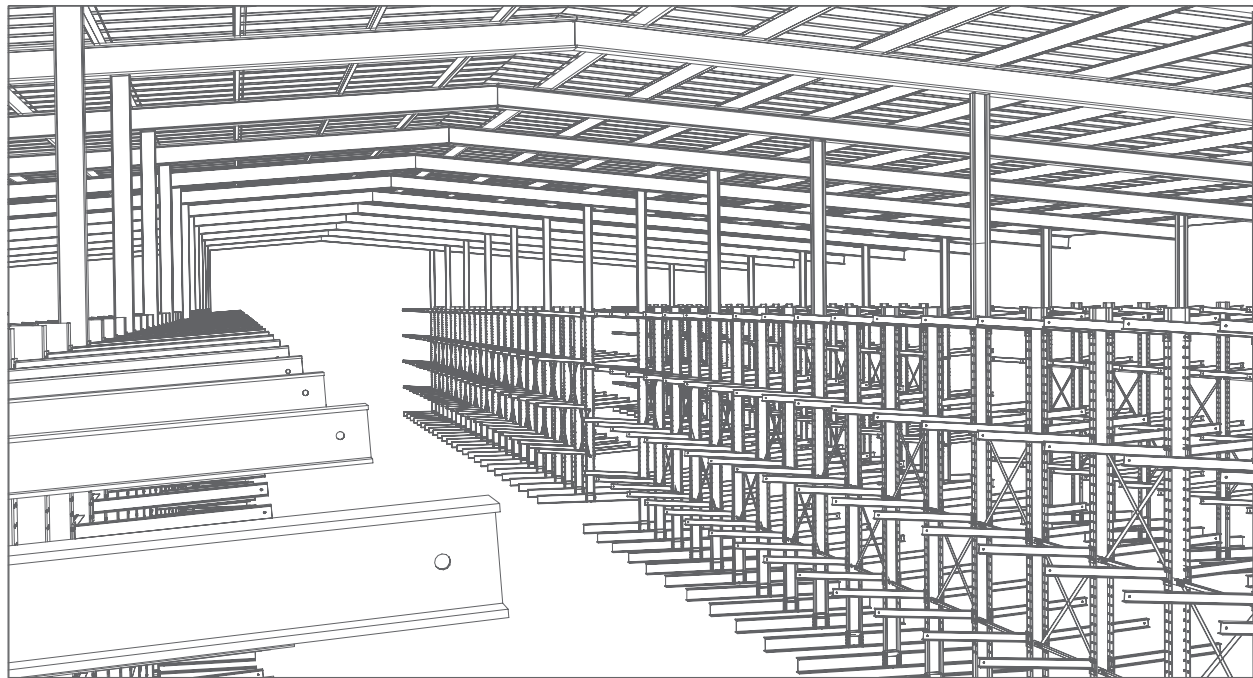

Reference the letter on the photo when speaking with your sales representative.





POPULAR DRIVE-THRU CONFIGURATIONS

Here are just a few of our most popular design configurations. Use them as a starting point for the design of your own custom building. All layouts can be customized to suit your company's unique requirements. A Sunbelt Rack representative can provide you with a preliminary design and quote.

Features

- Complete yard planning and site layout services (see pg 52)
- Engineered plans available throughout North America
- Installation services
- Accessories available (see pg 22)

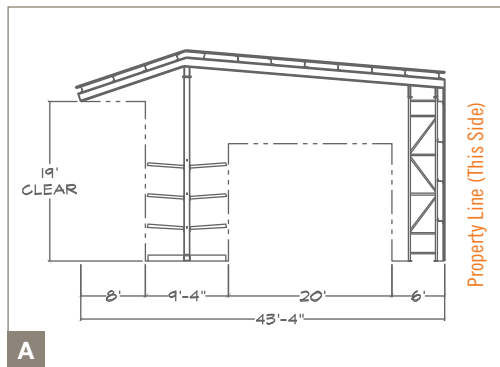

A Multi-Purpose Property Line Shed

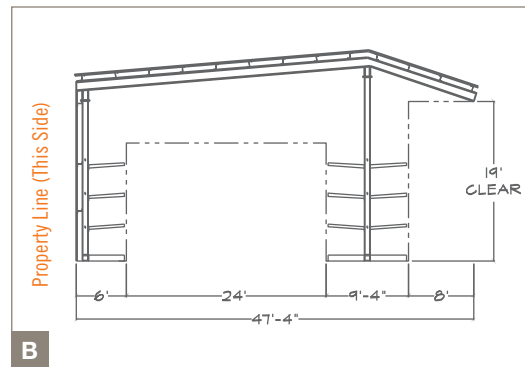

B Single-Aisle Property Line Building

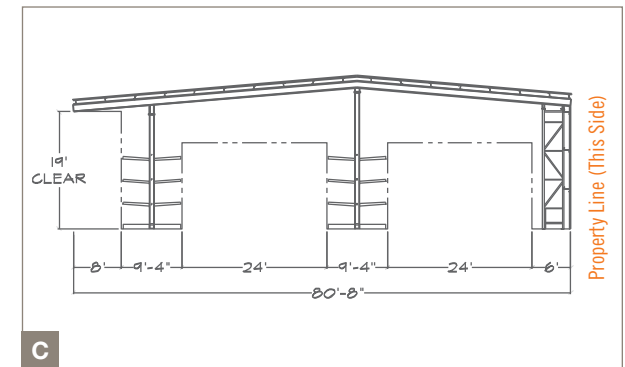

C Double-Aisle Property Line Building

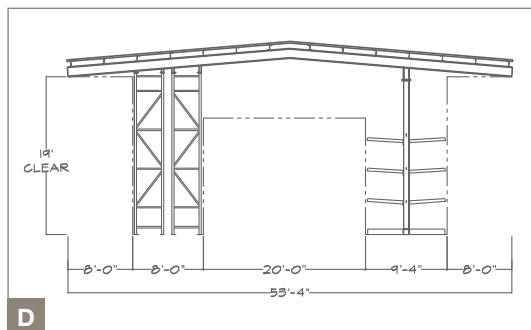

D Pallet Rack / Cantilever Building

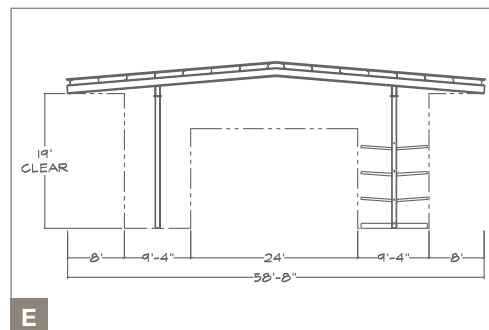

E Bulk Storage / Cantilever Building

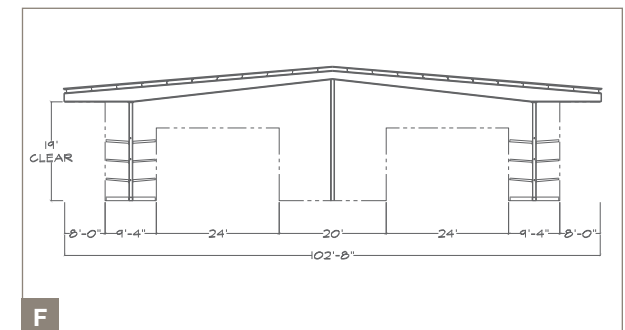

F Double-Aisle Cantilever Building

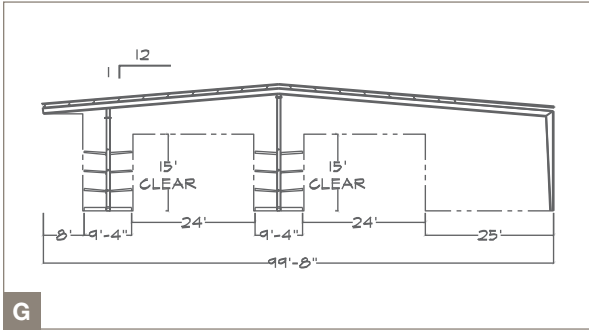

G
Double-Aisle Cantilever / Bulk Storage Building

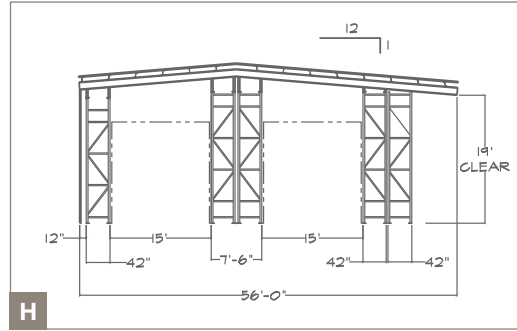

H
Double-Aisle Pallet Rack Warehouse

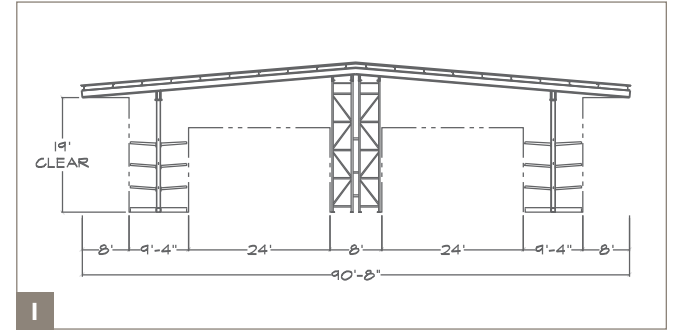

I
Multi-Purpose Double-Aisle Building

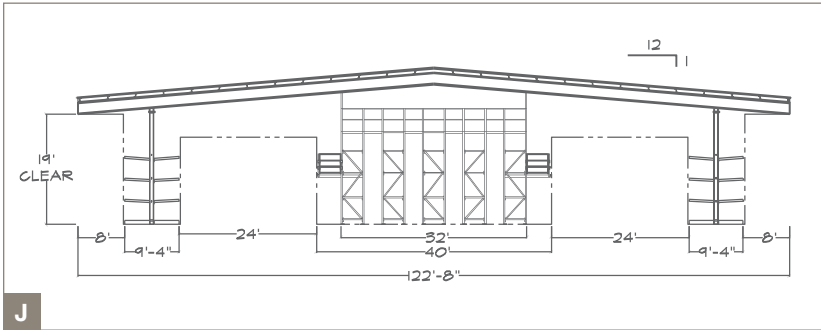

J
Double-Aisle Power Bin Building

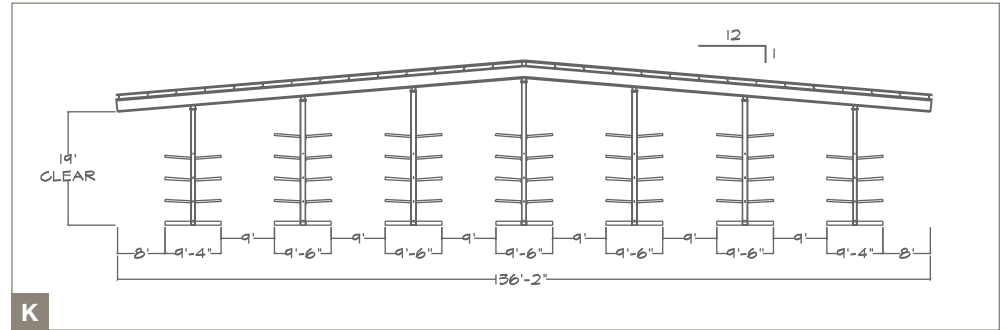

K
Narrow-Aisle Drive-Thru Building (for side loading forklifts)

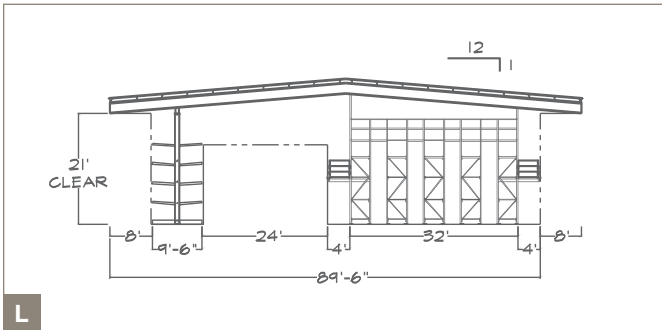

L
Single-Aisle Power Bin Building

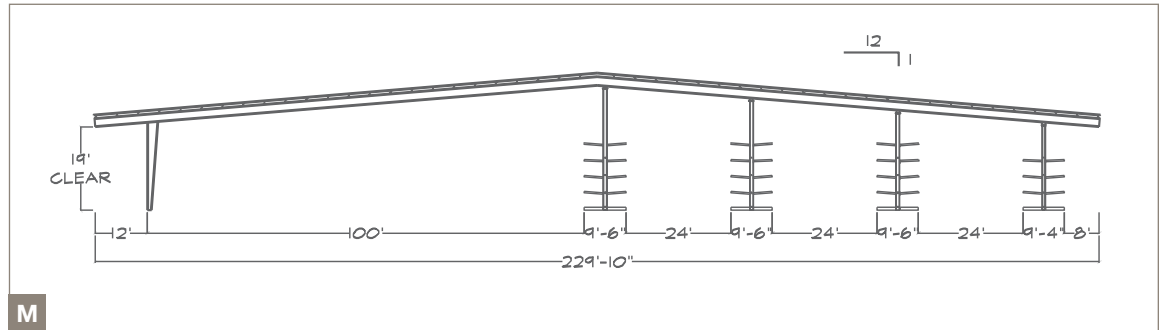

M
Multi-Purpose Clear Span Drive-Thru Building



ACCESSORIES

To be sure our rack systems and buildings meet your specific needs, we offer many different accessories and options. Your Sunbelt Rack representative can walk you through the ones for your particular racks or structures. Here are just a few of them.

Don't see the accessory you need? Wonder which ones are right for you? For advice or questions about our accessories, please call or visit our website.



1-800-353-0892



Sunbelt-Rack.com

Accessories

Use the letters below to reference the photos on the next page when speaking with your sales representative.

- A** High R-value insulation
- B** Closure panels between cantilever columns and endwalls
- C** Double-stack cantilever top arm level
- D** Endwalls
- E** Vapor barrier insulation
- F** Skylights
- G** Wall lights
- H** Extended overhangs
- I** Overhead doors
- I** Gable or ridge vents *(not pictured)*



“
From design concept through completion of installation, Sunbelt Rack handled everything and we could not be happier.
”
Doug LaBoube • McCray Lumber • Edwardsville, KS





STORAGE SOLUTIONS

We have what it takes to design, create and install storage and material handling solutions that are right for your business, your site and your budget. We offer a complete range of racks and racking systems from cantilever racks, pallet racks, stack racks to A-frame racks, mezzanines and specialty racks. Our rack-supported buildings include T-sheds, I-beams, L-sheds, automated Power Bins and more.

For advice or questions
about our storage
solutions, please call
or visit our website.



1-800-353-0892



Sunbelt-Rack.com

Section Table of Contents

- The automated Power Bin System 26
- T-Sheds 30
- L-Sheds 32
- I-Beam Cantilever Racks 34
- Millwork Racks 36
- Stack Racks 38
- Millwork Mezzanines 40
- Board Bin Mezzanines 42
- A-Frame Racks 44
- Drive-In/Drive-Thru Racks 46
- Push-Back Racks 48
- Roll-Formed Pallet Racks 48
 - Sheet Goods Racks*
- Structural Pallet Racks 50
 - Roofing and Bagged Goods Racks*
- Accessories. 22



power bin



THE AUTOMATED POWER BIN SYSTEM

The Sunbelt Rack automated Power Bin is an innovative rack system that automatically handles and stores lumber, plywood, vinyl siding, MDF molding, composite decking, metal roofing, slab doors and other building materials. A battery-operated loader deck automatically loads material into pigeonhole-type bins equipped with heavy-duty rollers. Loading takes approximately one minute.

We tailor the bin configurations to each customer's unique needs. Bins also offer manual order picking, with catwalks to access the upper rows. A Power Bin system can easily incorporate mezzanine storage and can also form the support structure for a shed or become part of a rack-supported drive-thru building.

Features

- Stores building materials from lumber, plywood, vinyl siding, MDF molding, composite decking to metal roofing
- Incorporates pigeonhole-type bins equipped with heavy-duty rollers
- Loads material into the bin automatically using a battery-operated loader deck
- Can form the support structure for a shed or become part of a rack-supported, drive-thru building (*see pgs 4-21*)
- Can be part of a comprehensive Sunbelt Rack yard and site layout (*see Planning & Design, pg 52*)
- Can be combined with Sunbelt Rack's other storage systems for maximum efficiency
- Engineering and installation available throughout North America



Load a full bundle of lumber in approximately one minute!



Visit Sunbelt-Rack.com and click "Power Bin Video" to see more.

Reference the letter on the photo when speaking with your sales representative.



“
The Power Bin is as efficient and modern as I've ever seen.
”
Al Bavry, Owner
Kimal Lumber • Venice, FL





MORE ABOUT THE AUTOMATED POWER BIN SYSTEM



An automated Power Bin system will give you numerous efficiencies. Most significantly, it eliminates unnecessary labor. Since you will no longer need to hand-load bins, you will save man-hours, reduce damage and waste and reduce the chance of employee injuries. By storing materials “up” rather than spreading them out, it lets you conserve valuable warehouse space. It also keeps everything well organized, neat, clean and easily accessible. An automated Power Bin can easily pay for itself in just a few years.

Features

- Configured to each customer’s unique needs
- Offers both automatic and manual material picking
- Eliminates hand-loading
- Saves man-hours
- Minimizes product damage and waste
- Reduces the chance of employee injury
- Keeps materials well organized, neat, clean and easily accessible
- Is typically 4 bins high, with top 2 bins accessible from a catwalk
- Offers quick payback from space savings, efficiency gains and reduced product damage

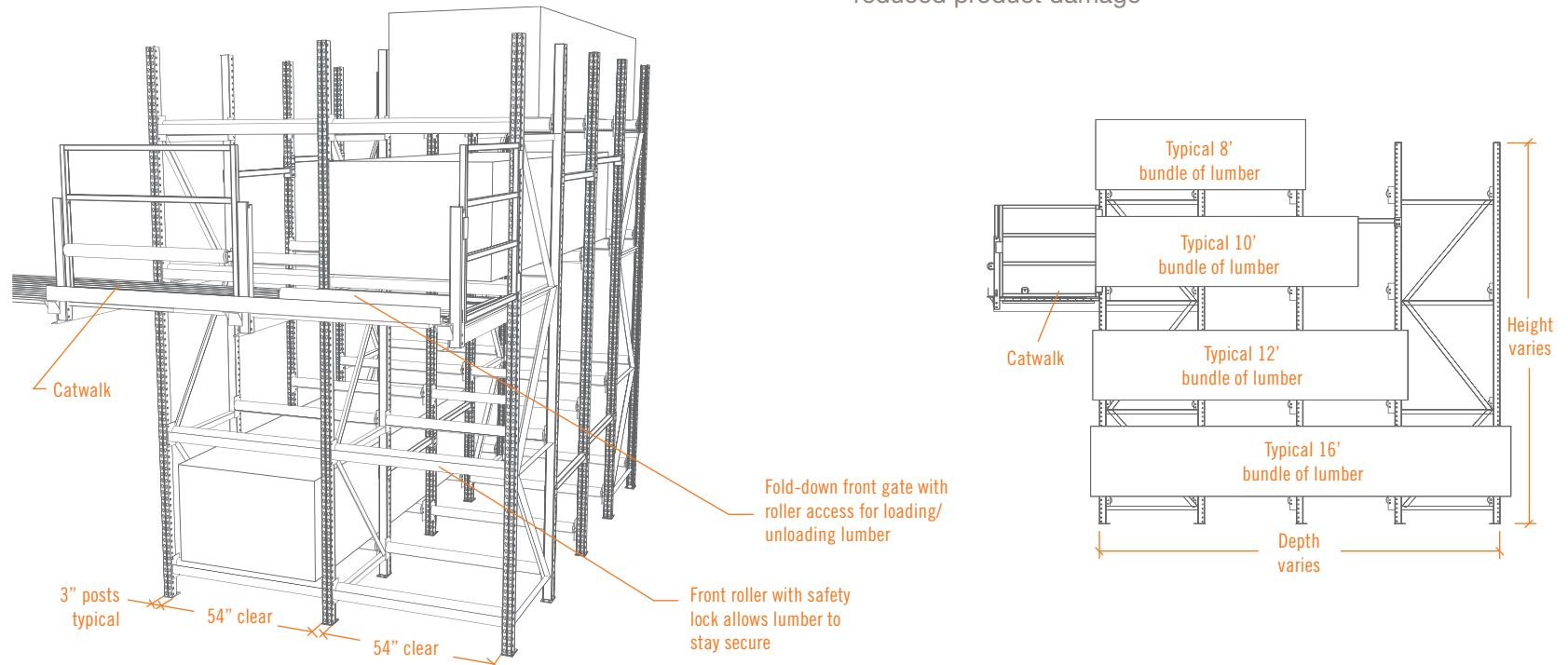

Reference the letter on the photo when speaking with your sales representative.





T-SHEDS

Sunbelt Rack's custom-designed T-sheds provide high-density storage with pick access for long-length materials, thus protecting your inventory of dimensional and treated lumber, and engineered products from the weather. The results are less weather-related damage and loss and greater operating and cost efficiencies gained from better organization and elimination of unnecessary material handling.

Features

- Custom designed to suit your unique needs and site
- Overall roof widths from 16' to 30'
- 3, 4, or 5 levels of storage available
- Supported by complete yard planning and site layout services (*see Planning & Design, pg 52*)
- Engineered plans available throughout North America
- Installation service available
- Accessories available (*see pg 22*)

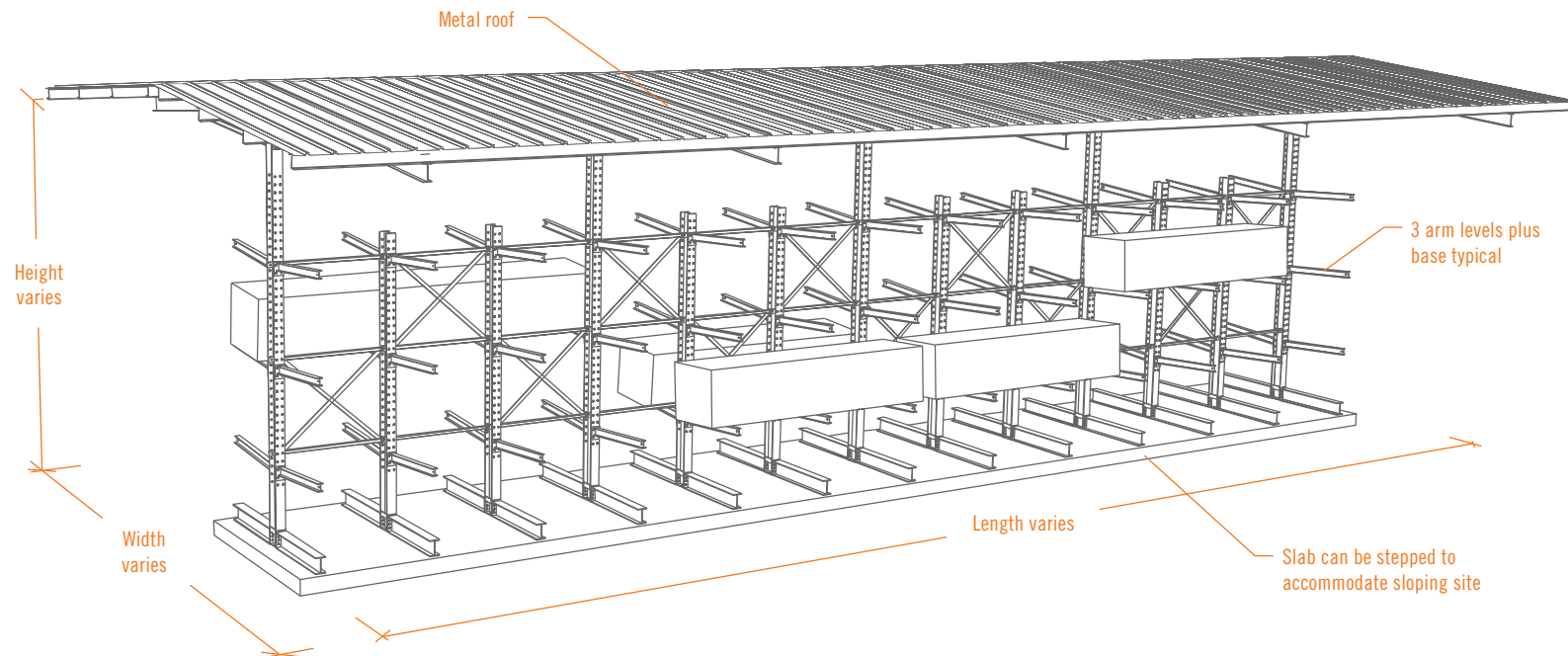

*Reference the letter on
the photo when speaking with
your sales representative.*





L-SHEDS

Sunbelt Rack's custom-designed L-sheds provide high-density storage with pick access for long-length materials, thus protecting your inventory of both dimensional and treated lumber and engineered products from the weather. The results are less weather-related damage and loss and greater operating and cost efficiencies gained from better organization and elimination of unnecessary material handling.

Features

- Custom designed to suit your unique needs and site
- Overall roof widths from 8' to 15'
- 3, 4, or 5 levels of storage available
- Supported by complete yard planning and site layout services (see *Planning & Design*, pg 52)
- Engineered plans available throughout North America
- Installation service available
- Accessories available (see pg 22)

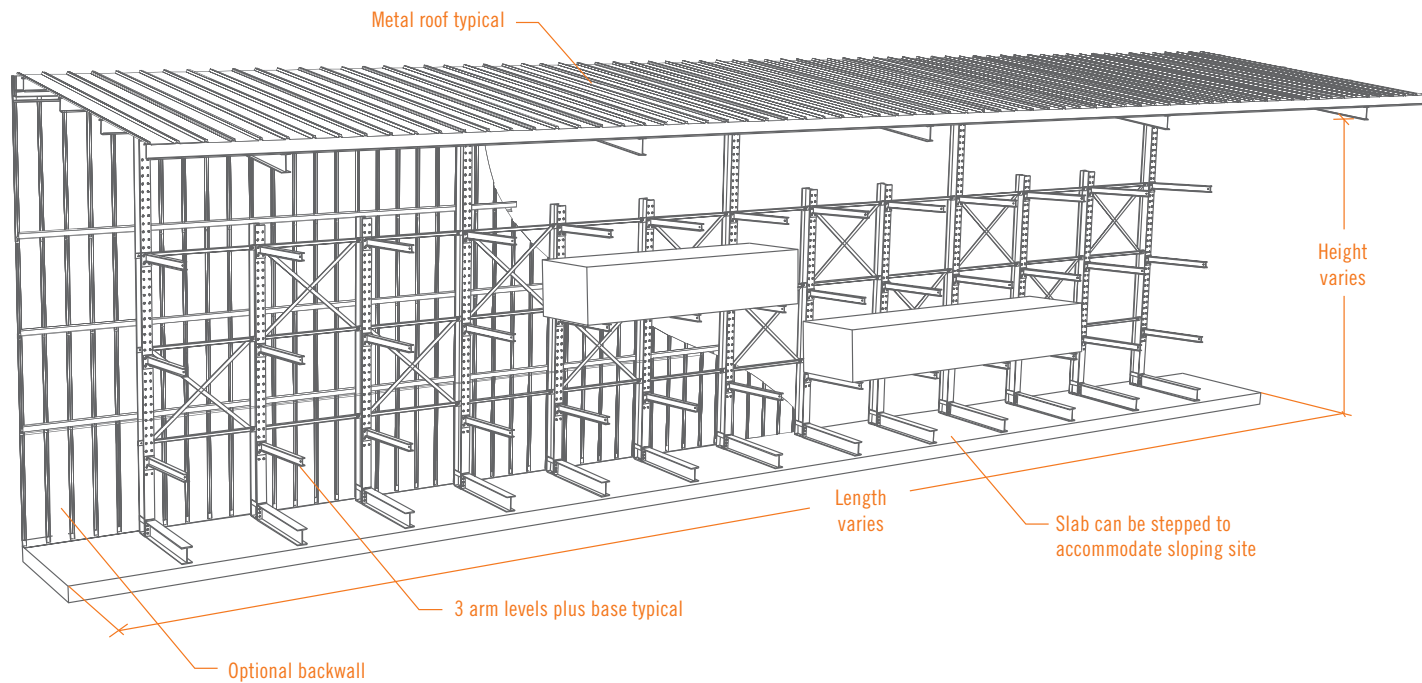

Reference the letter on the photo when speaking with your sales representative.



“
To make something like this work, it takes trust on both sides and a commitment to detail. This was a team effort from the very beginning, and Clint [Darnell] was patient with me throughout the process.
”
Barrett Burt, General Manager • Ganahl Lumber • California





I-BEAM CANTILEVER RACKS

The versatile Sunbelt Rack structural steel I-beam cantilever rack is the building block of many of our T-sheds, L-sheds and drive-thru buildings, but it can also function as a stand-alone multi-level high-density storage system for long-length materials. It is the most efficient and affordable way to store lumber, engineered wood products, rebar, and metal roofing and pipe. It's so rugged you can use it indoors or out. Whether used as a stand-alone storage unit or support for the roof of a shed or building, it's economical and versatile.

Features

- Constructed of structural steel I-beams
- Double- and single-sided configurations available
- Different column and arm sizes available to suit various load requirements
- 3, 4, or 5 levels of storage available
- Arms adjust vertically in 4" increments
- Bolted arm and base connections
- Installation service available

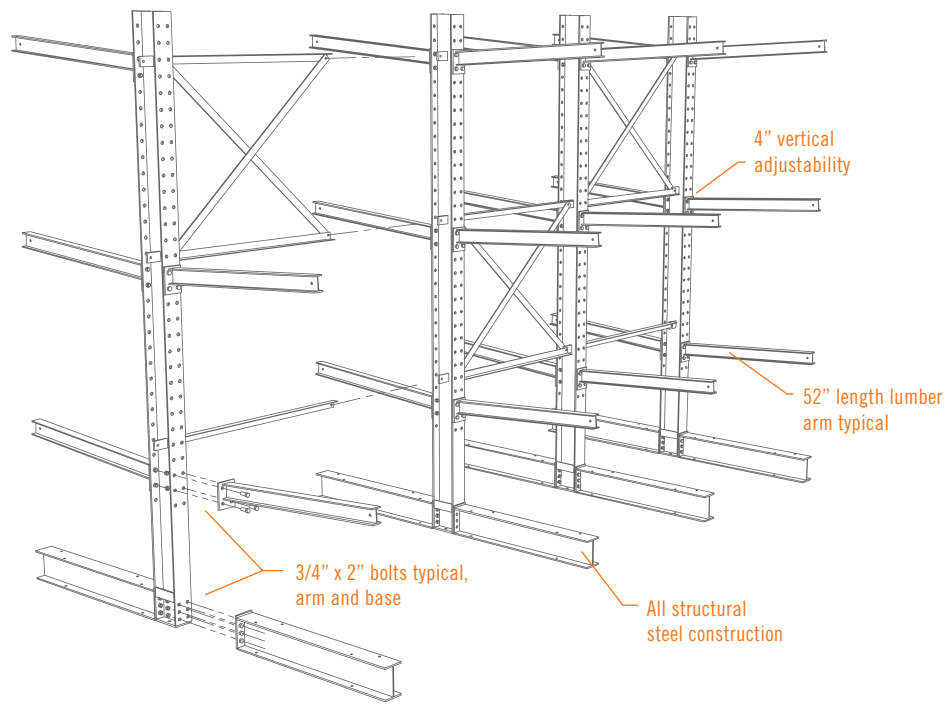

Optional removable safety retainer bar with chain



Optional plastic safety end cap

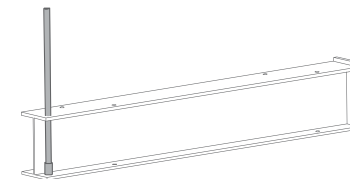

Optional removable base safety retainer bar

Reference the letter on the photo when speaking with your sales representative.





MILLWORK RACKS

Our millwork racks are movable, stackable storage systems for windows, doors and other products. Because they're movable, you can load millwork onto them directly at the assembly area and then move them to a warehouse or staging area. Because you can stack them up to three racks high, you can arrange them densely and thereby eliminate aisles and save warehouse floor space. They can even be loaded directly onto a delivery truck used in conjunction with curtain vans and piggyback lifts and thus eliminate manual loading and unloading.

Features

- Constructed of rugged steel
- Stackable 2 and 3 high (3 high in non-seismic areas only)
- Integrated fork pockets on all 4 sides
- Designed for plywood deck
- Carts available to move racks to facilitate building orders within your facility
- Can eliminate manual loading and unloading of trucks when used with curtain vans and piggyback lifts

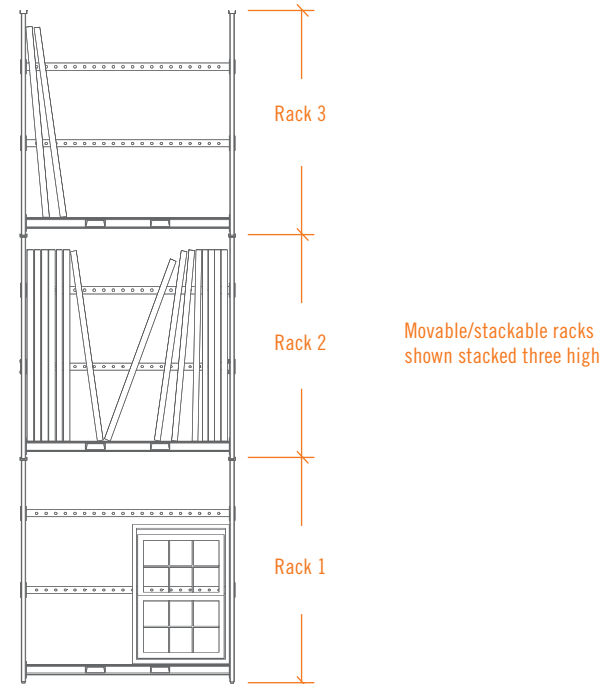
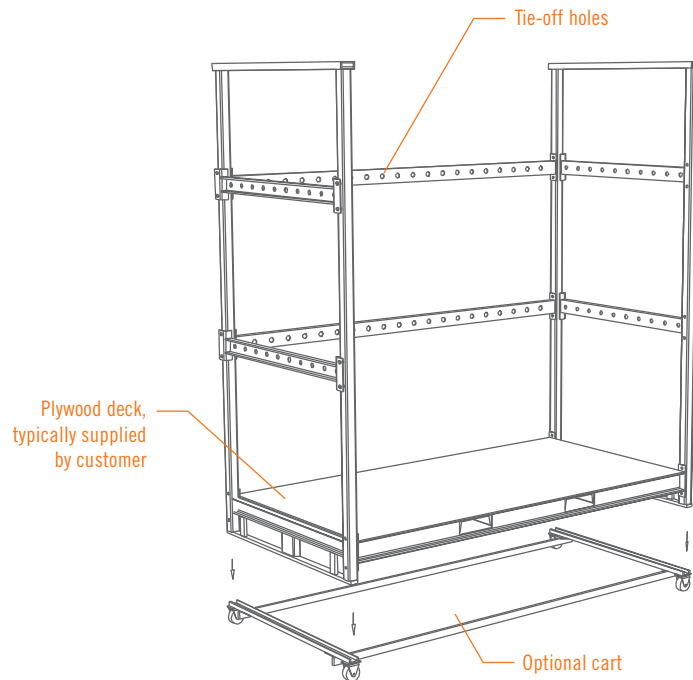

Reference the letter on the photo when speaking with your sales representative.



“
The experience was excellent.
They did everything they said they
would – on time and on budget.
There were no false promises.

”

*Bob Sanford, Owner
Sanford & Hawley, Inc. • Unionville, CT*





STACK RACKS

Our stack racks are movable, stackable storage systems whose size, capacity and quantity can be tailored to virtually any product. Because they're movable, you can arrange them densely and thereby eliminate aisles and save valuable warehouse floor space. Because their posts are typically removable, you can save even more space by knocking them down for storage when not in use. Since our stack racks reduce product damage and unnecessary handling, you'll also enjoy a quick investment payback.

Features

- Numerous size and weight capacities available
- Various base configurations (dimensions A & B shown below)
- 2- or 4-way entry options available
- Constructed of rugged steel
- Stackable 3 and 4 high
- Removable posts for easy knockdown and storage
- Different deck options available (plywood, steel, no deck)

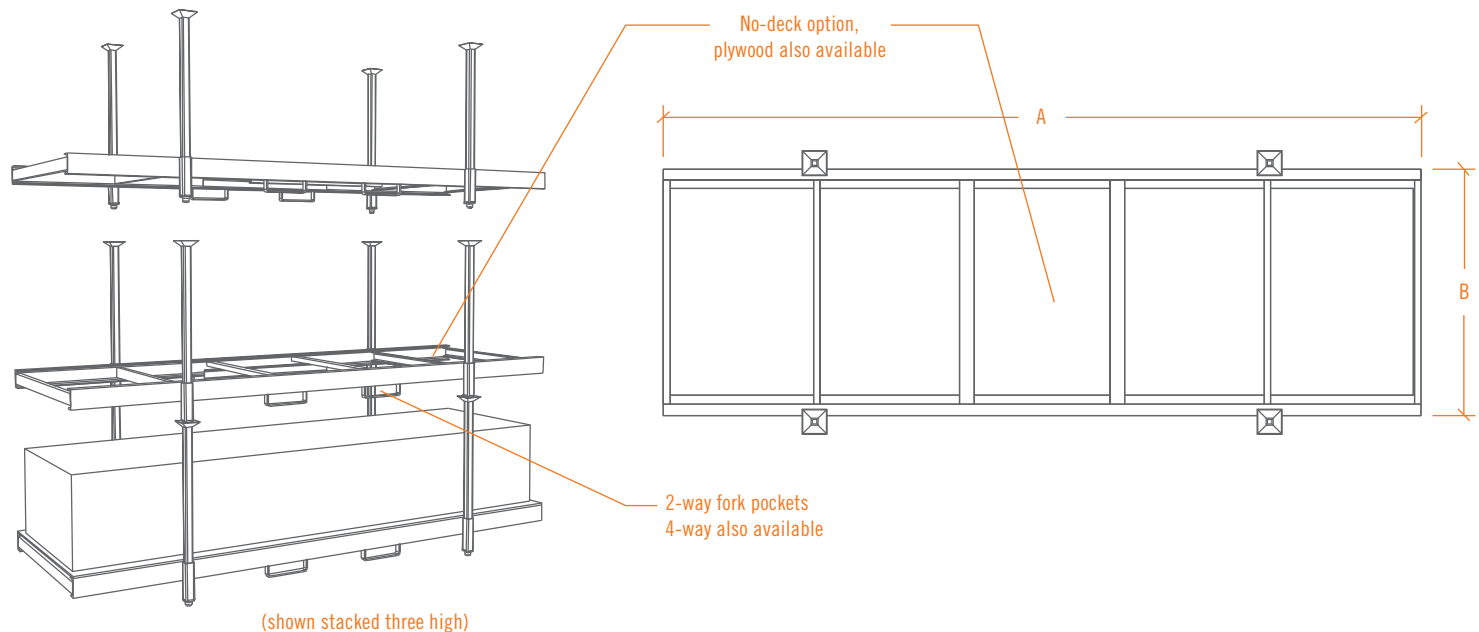

Reference the letter on the photo when speaking with your sales representative.



A



B



C

“
In the LBM world, it's not just about storing your lumber; it's about maximizing your space and your operation. Inventory management and product turn is essential – and in this business, efficiency wins every time.
”

*Travis Darnell, President and Co-Owner
CT Darnell Construction & Sunbelt Rack • Alpharetta, GA*



D



E



MILLWORK MEZZANINES

Our millwork mezzanines offer efficient, high-density custom-engineered storage for doors, windows and other products. A typical system places window and door storage on the floor level, with the products standing in bays of racking conveniently separated by dividers. The upper mezzanine level can have additional bays of rack storage or an open floor area for pallet or bulk storage. Our mezzanines also include access stairs and swing gates for lift truck loading, with numerous floor system options, from plywood to bar grate.

Features

- M- and V-dividers are typically used to separate doors and windows; different sizes available
- Open storage for bulky or palletized items easily incorporated

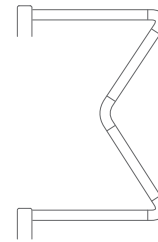
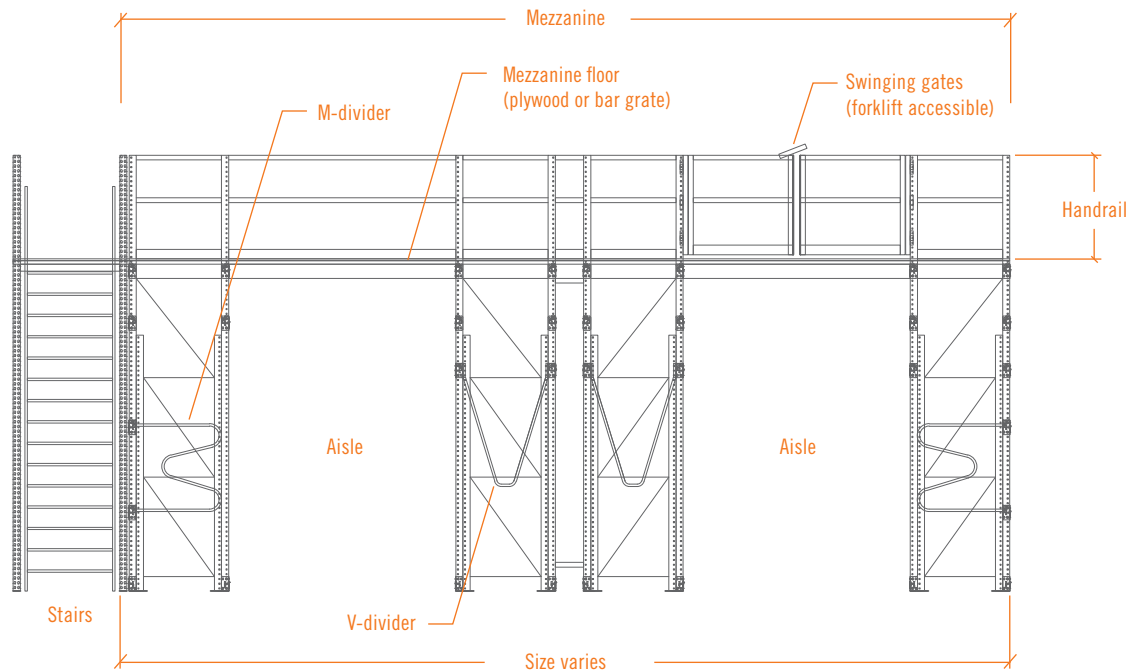

M-divider

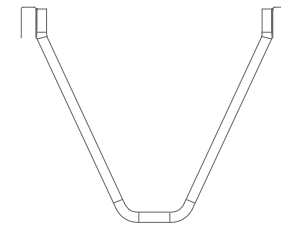

V-divider

Reference the letter on the photo when speaking with your sales representative.





BOARD BIN MEZZANINES

Our board bin mezzanines give you maximum storage in small areas. Hand-load long-length items such as lumber, pipe and vinyl siding into pigeonhole-type bins, with your choice of any number of openings in any height, width or depth. Other options include additional bins on the upper levels accessible from a front catwalk or a mezzanine floor for bulk or pallet storage. Each board bin is specifically designed for your unique requirements and loading conditions. For an automated option, please see our automated Power Bin System on pages 26-29.

Features

- Vertically adjustable bin sizes
- Modular construction for easy design and capacity variations
- Staircases, catwalks and mezzanines easily incorporated

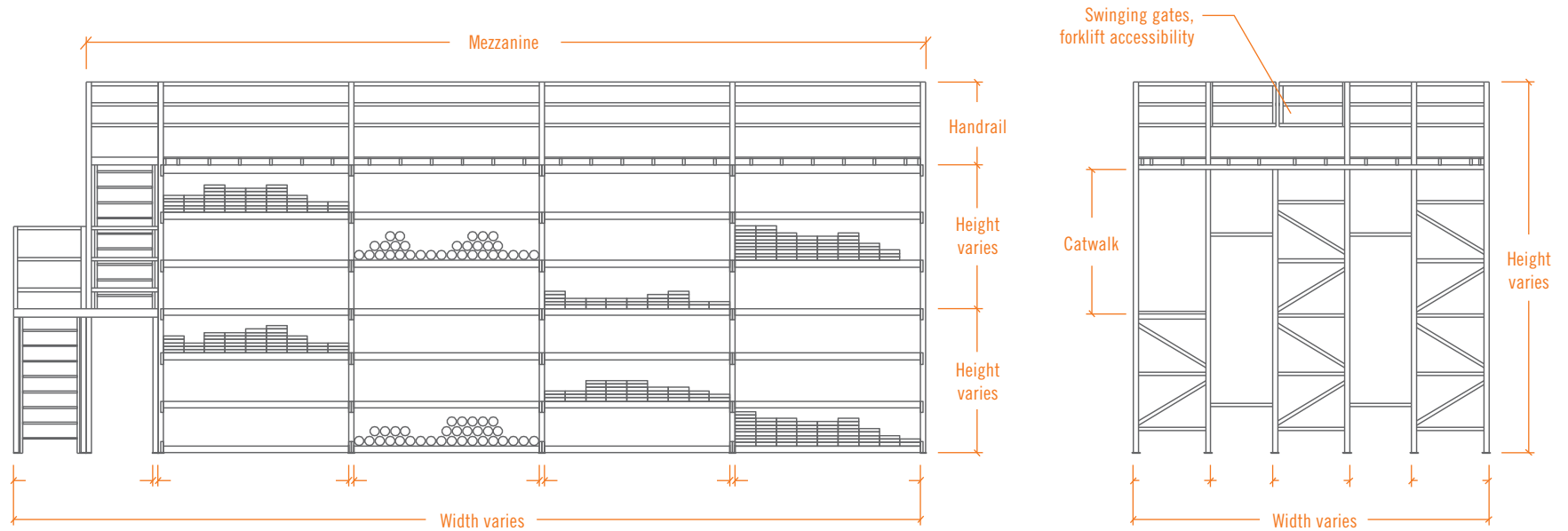

Reference the letter on the photo when speaking with your sales representative.



A



B



C



D



A-FRAME RACKS

- Safe storage and organization of molding boards, pipe, gutters, etc.
- Enhanced product accessibility and order picking
- Available as single-sided A-frame units or as attached units that create double-sided A-frame units
- Can accommodate runs of any length
- Varying base and deck depths available

Double-Sided A-Frame

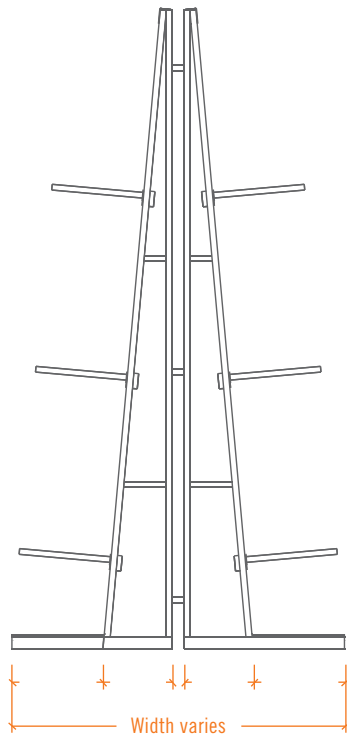

Single-Sided A-Frame

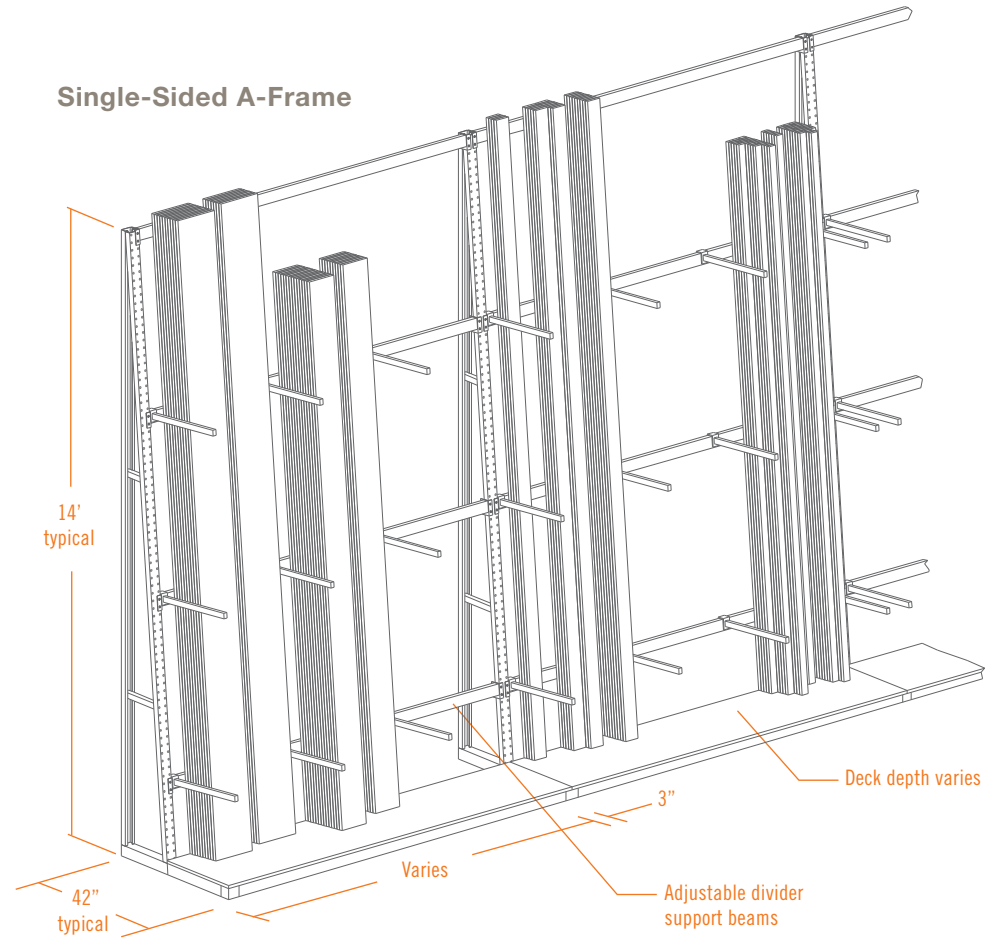

Reference the letter on the photo when speaking with your sales representative.



A



B



C



D



E



DRIVE-IN / DRIVE-THRU RACKS

Durable, versatile Sunbelt Rack drive-in and drive-thru racks provide high-density storage and eliminate wasted aisle space.

Features

- First in/last out or first in/first out order picking
- Structural steel construction for durability
- Pallet positions configurable from 2-5 deep and 2-5 high
- Ideal for roofing

Drive-In Rack

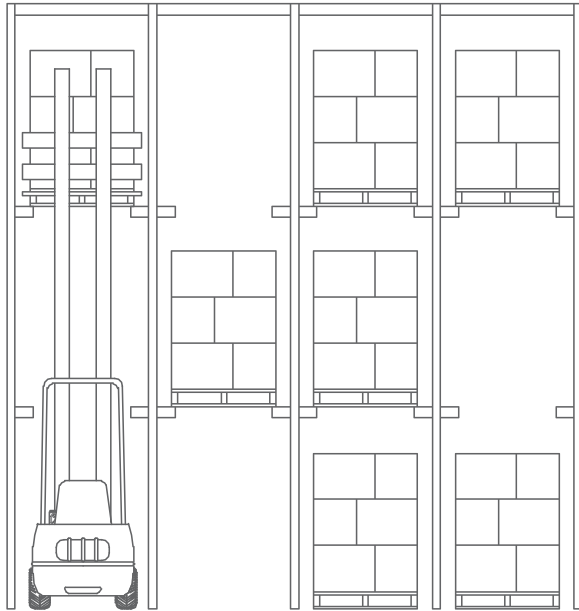

PUSH-BACK RACKS

Sunbelt Rack's push-back systems provide high-density storage that is ideal for diverse inventory.

Features

- Rolling carts are gravity fed to the aisle for easy loading and unloading
- First in/last out system
- Pallet positions configured from 2-5 deep and 2-5 high

Push-Back Rack

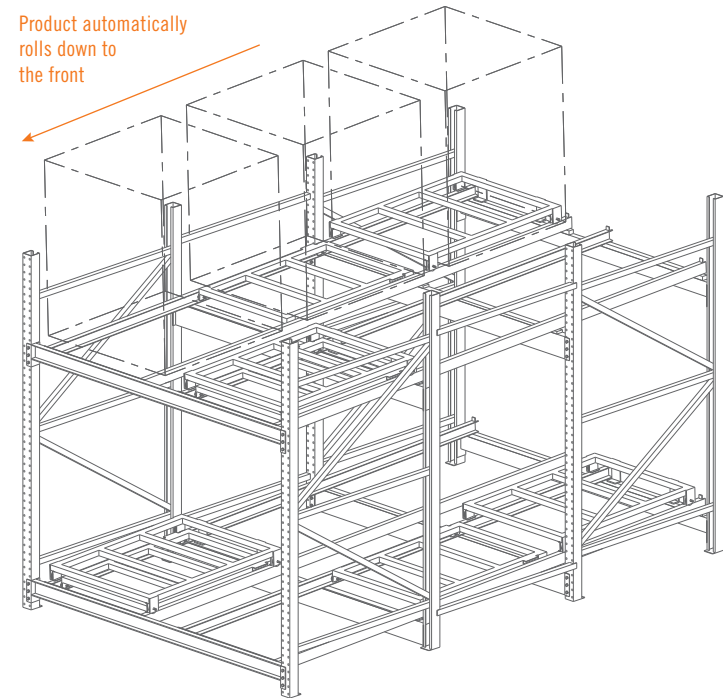

Drive-In / Drive-Thru Rack

C D

Push-Back Rack

A B E

*Reference the letter
on the photo when
speaking with your
sales representative.*



“
We were able to use a push-back rack system that allowed us to actually triple our capacity in the same footprint.
”
Barrett Burt, General Manager • Ganahl Lumber • Pasadena, CA





ROLL-FORMED PALLET RACKS

Versatile Sunbelt Rack roll-formed pallet racks are the building blocks of most warehouse storage systems. We can configure them to handle virtually any product, including retail merchandise, palletized items, building materials and especially sheet goods and roofing.

Features

- Boltless, snap-together assembly
- Shelves adjust vertically in 2" increments
- Various capacities to suit your storage needs
- Custom sizes and colors available
- Pallet support bars, fork entry bars, and wire mesh decking available

Sheet Goods Racks

- Economical, convenient storage for plywood and particleboard
- Narrower openings available for paneling storage
- Individual units easily and safely forklift accessible
- Available fork entry bars for sheet goods storage

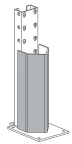

POST PROTECTOR
Provides extra protection against damage from forklifts and other retrieval equipment.

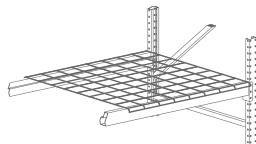

WIRE MESH DECKING
Wire grid deck for step or box beams. Open mesh construction permits free passage of water, light, air. (Roll-formed and structural steel)

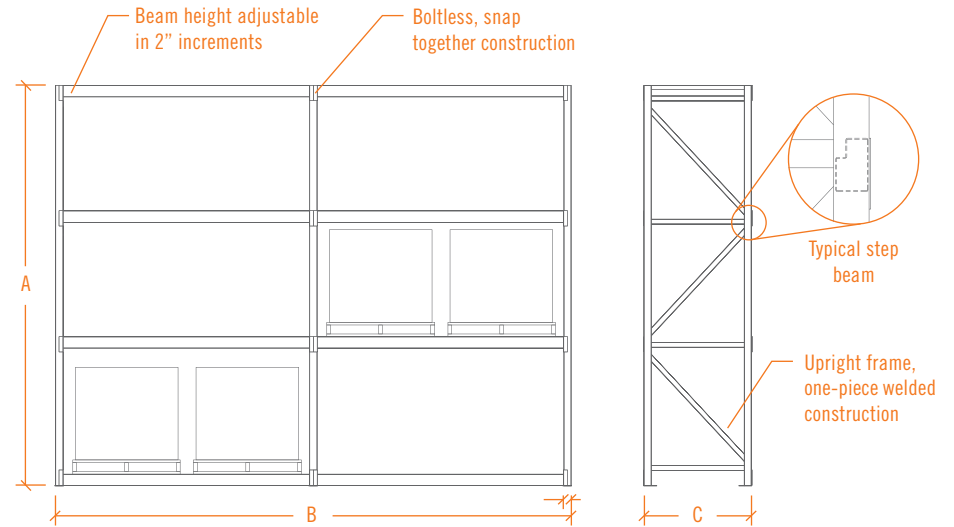

A, B, C = any dimension available

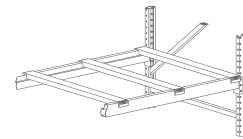

PALLET SUPPORT BAR
Front-to-back member used to support pallets or decking. (Roll-formed and structural steel)

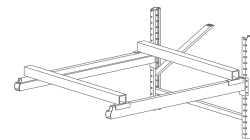

FORK ENTRY BARS
Provides ample clearance for insertion of standard forks under sheet goods. (Roll-formed and structural steel)

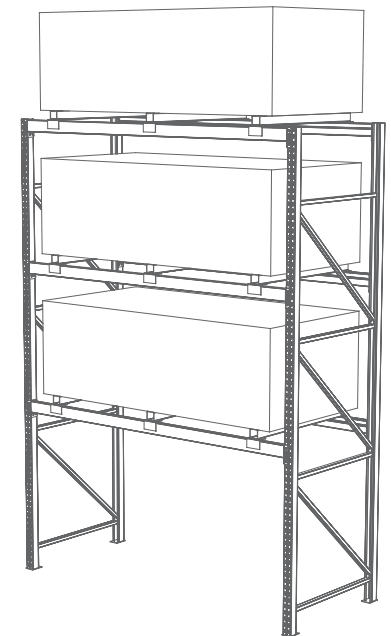

Sheet Goods Rack

Reference the letter on the photo when speaking with your sales representative.





STRUCTURAL PALLET RACKS

Sunbelt Rack's structural steel pallet racks offer the same versatile storage as our roll-formed pallet racks with the advantage of rugged structural steel construction. We can configure them to handle virtually any product, especially in high-abuse environments.

Features

- Bolted connection, shelves adjust vertically in 2" increments
- Rugged, structural C-channel design
- Resistant to forklift truck damage
- Ideal for materials requiring high weight capacity
- Good for outdoor use
- Pallet support bars, fork entry bars, and wire mesh decking available (see pg 48)

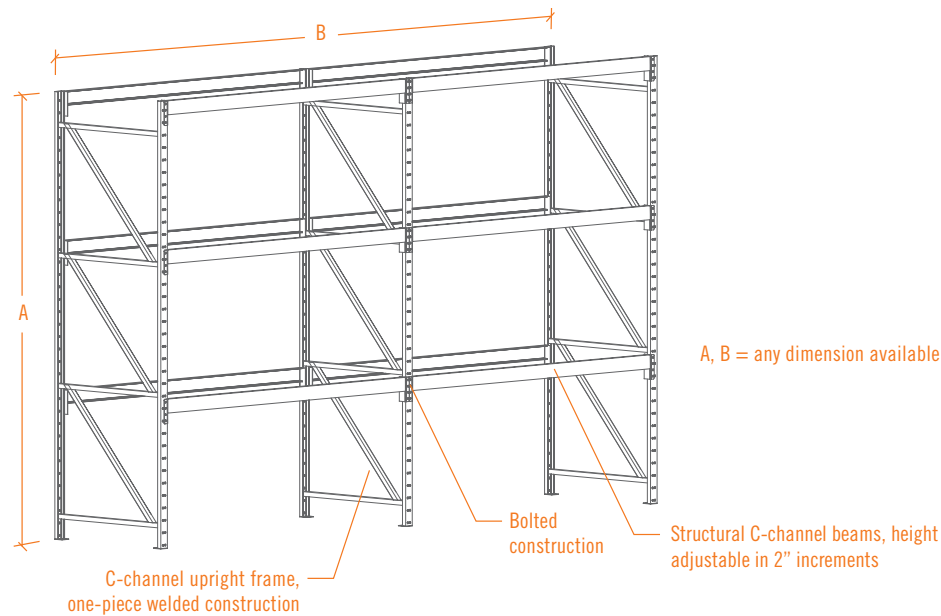

Roofing and Bagged Goods Racks

- Ideal for all heavy palletized materials, including shingles, felt, concrete mix and joint compound
- Heavy-duty construction to resist damage
- Significantly increases vertical storage
- Eliminates roofing product warranty issues due to direct pallet stacking

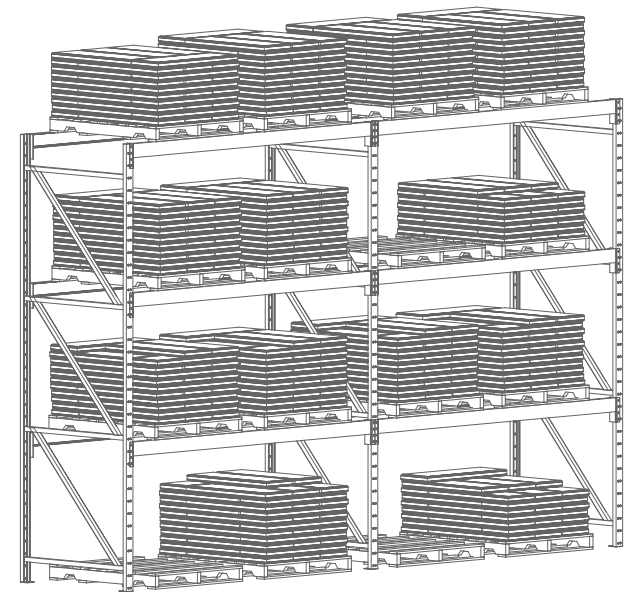

Roofing and Bagged Goods Rack

Reference the letter on the photo when speaking with your sales representative.



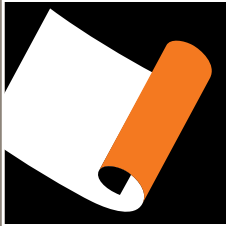

PLANNING & DESIGN

For over a quarter of a century, Sunbelt Rack has supported LBM businesses with an extensive supply of storage solutions and steel buildings. In partnership with our sister company, CT Darnell Construction, we also offer warehouse layouts, yard planning, and building design for both new sites and renovations.

Features

- Warehouse layouts, rack configurations and product plan-o-grams
- Traffic flow, shipping and receiving systems design
- Full-service engineering and architectural services
- Site feasibility studies and planning
- Building design and budgeting, either separately or as part of a larger building project
- Inventory organization and handling
- Building and rack installations



Need help planning your next step? For a free consultation, please call or visit our website.



1-800-353-0892



Sunbelt-Rack.com

Product Plan-o-gram **A**

Site Layout **B C**

Reference the letter on the photo when speaking with your sales representative.

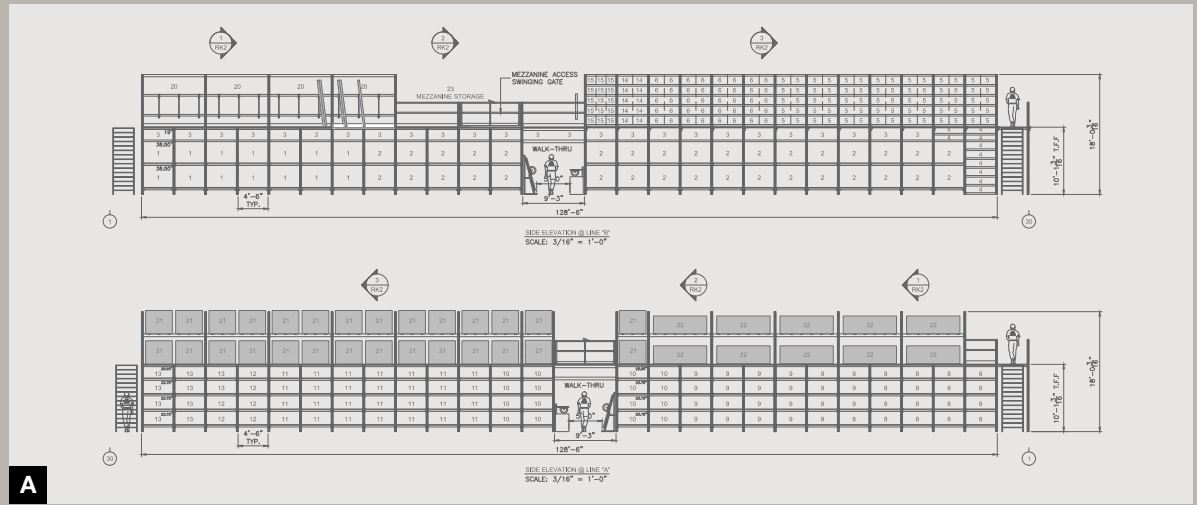
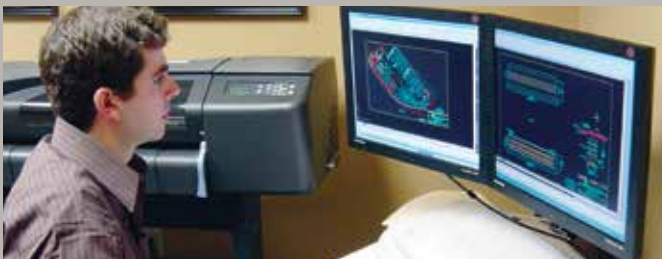
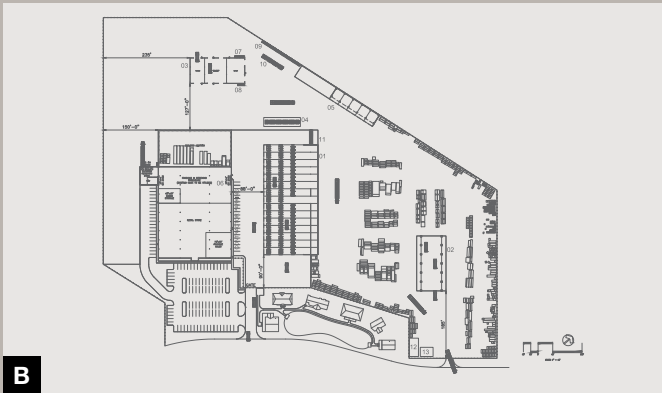

“ Sunbelt Rack took the time to understand our business and our needs, and helped us come up with an innovative design to more efficiently serve our customers both today and in the future. ”

Matt Bruce, VP • E.L. Morse Lumber • Wareham, MA

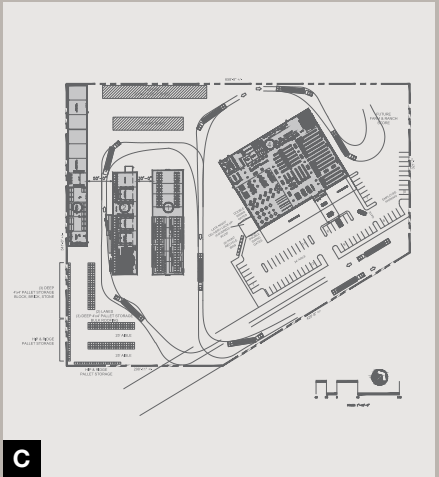



GENERAL CONTRACTING & CONSTRUCTION



In partnership with our sister company, CT Darnell Construction, we've built solutions for more lumber and building material

retailers than any other company in North America. We have worked at hundreds of locations, designing and building retail facilities, warehouses, and production facilities for hardware stores, lumberyards, and building material wholesalers.

Projects range from green field sites to expansions and remodels, to integrated rack-supported building systems. Our team of designers and project managers can oversee your project from start to finish, providing unmatched value and expertise.



Would you like to know more about our general contracting and construction capabilities? For a free brochure or consultation, please call or visit our website.



1-800-353-0892



CT-Darnell.com



Reference the letter on the photo when speaking with your sales representative.



C



D



A



B



E

“
CT Darnell has worked with us on numerous projects, delivering them on time and on budget. They always found creative ways to resolve the inevitable challenges that arise.

”

Mark Jackson, AIA
Croft & Associates • Kennesaw, GA



SUPPORT FOR YOUR LUMBER AND YOUR BUSINESS.

Sunbelt Rack • 2255 Justin Trail • Alpharetta, GA 30004

 1-800-353-0892

 770-569-9944

 Sunbelt-Rack.com